

Intelligent Portion Cutter

PORTIO



- High speed cutting:
Fixed weight, fixed thickness
- High precision, minimal give-away
- Flexible software
- Easy to clean
- Labor saving options



Features



The PORTIO combines state of the art technology for creating a high precision yet economic portion cutting machine.



**High speed cutting:
fixed weight
fixed thickness**



It is suited for fresh products such as fish fillets, whole fish, meat and poultry products. According to the product type, different product fixation systems are possible. Different knife types, suited for the product, can be used.

**High precision
minimal give-away**

A product is fed on the infeed belt. A three dimensional laser scanner then calculates the weight. The PORTIO computer then calculates where to cut. Each product with its cutting pattern is displayed as a 3D color image.



Easy to clean

The machine can be completely opened for fast and easy cleaning. The belts can be taken out for separate cleaning.

PORTIO 1 PORTIO 3

Principle

Portio 1 : camera 1
Portio 3 : camera 1+2+3

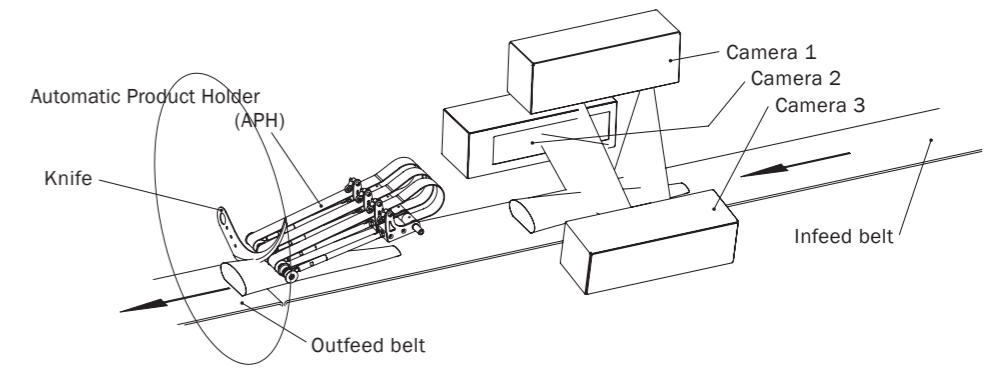

Intelligent portion cutting

Pre-programmed calibration enables you to switch product setups in seconds. Specialised programs ensure a highly flexible portioning solution that always makes the right decision prior to the actual cutting. The portion cutter can be adjusted from the color screen control panel at any time during the portioning process, which improves performance.



Ultra fast cutting

The knife makes up to 1000 fixed weight cuts per minute.



DIMENSIONS

PORTIO 1	
l x w x h	135 x 43 x 63 inch
net weight	2095 lb

PORTIO 3	
l x w x h	135 x 51 x 63 inch
net weight	2430 lb



Modular belt

The modular belt combines perfect synchronisation with unrivalled lifetime. Automatic stretch compensation guarantees accuracy over the years with the same belt.



Unmatched accuracy

The latest laser vision technology, featuring a 400 Hz camera, ensures unparalleled accuracy.

- 1 laser camera for flat products such as fillets
- 3 laser cameras to scan the contour of more rounded products



Extremely hygienic

The PORTIO is designed and built to comply with the most stringent hygiene standards. A CIP (cleaning in place) system guarantees a fast cleaning procedure for both belts and knife guidance.

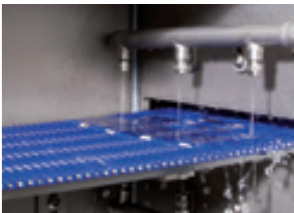

Maintenance

For maintenance, easy obtainable spare parts have been selected. This guarantees lowest possible maintenance costs. All motors and encoders are situated away from the wet area, which ensures a long lasting lifetime.



Options

APH

The Automatic Product Holder consists of four flexible arms. It holds down each piece of product on top which keeps it stable and helps prevent it from moving on the conveyor belt during cutting. The APH is driven by drum motors, no transmission chains, and is easily adjustable.

BH

The Back Holder assures that the last portions on high products remain upwards to assure precise portioning till the last piece, for optimum use of the whole product to give maximum yields.

OPH

The Outfeed Product Holder separates the exact weight portions from each other before they go onto the inline weighing unit of the grader.

Retractable

The retractable outfeed belt eliminates automatically the head trim and/or tail trim by retracting the outfeed belt. An optional blow off system assures that those trims are separated from the other portions.

MBE Software

MARELEC Bright Eye – MES software connects the PORTIO with graders, scales, terminals, bar code readers etc., to control and trace the entire flow starting from receiving, stock of raw

materials, processing, labeling, stock of finished products, all the way to dispatch.

PORTIO 350

For products exceeding certain dimensions, both the PORTIO 1 and PORTIO 3 can be equipped with a belt of 350 mm wide.

PORTIO 1A PORTIO 3A

PORTIONING under ANGLE

Identical capacity and precision, different presentation of the portion



Designed to give a natural look on sliced portions, yet keeping the accuracy, the PORTIO 1A, PORTIO 3A, as well as the PORTIO 1DA allows the operator to change the cutting angle from 0° to 30° or 45°. Slicing under angle can be done at the same speeds as the standard PORTIO.

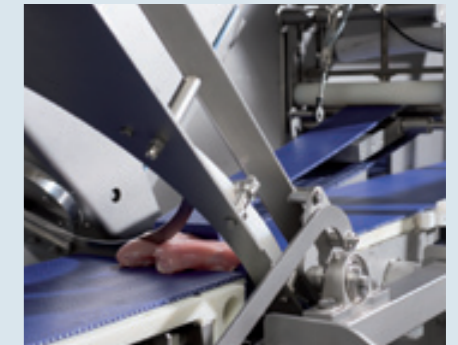

Changing the angle is fast and easy without the use of tools. The optimum gap between the infeed and outfeed belt is adjusted automatically (patent pending).

0°



30°



45°



DIMENSIONS

PORTIO 1A/3A	
l x w x h	138 x 55 x 63 inch
net weight	2505 lb

PORTIO in line with GRADER

Yields can be improved tremendously when the intelligence of the PORTIO divides the primals into portions of various programmed weights or sizes. All portions will be exactly within the required tolerances and according to the priorities. The MARELEC MC3 outfeed catchweigher, in line with the PORTIO, brings the same weight portions back together. Number of stations, type of grading arms and bins are designed according to your specific products.



Specifications

Product dimensions :

PORTIO 1 : 1000 x 240 x 150 mm
39,4 x 9,5 x 6 inch

PORTIO 3 : 800 x 240 x 150 mm
31,5 x 9,5 x 6 inch

Continuous infeed without space between products possible

Belt width : 254 mm / 10 inch

Belt speed : up to 600 mm/s / 2 ft/s

Possible to start and stop to group the portions

Cutting rate : up to 17,5 cuts/s

Construction : stainless steel AISI 304 and FDA approved food plastics

Conveyor belt : modular type

Selection keyboard :

IP67 with integrated electronics

Indicator : MARELEC Z1

Power supply :

3 x 380 V + N / 50-60 Hz / 5 kW

Other power supplies available

Air supply : 6 bar / 87 psi (APH)

Cleaning :

designed for optimal cleaning to meet extreme hygiene standards (CIP integrated)

Software :

MARELEC P1 standard optimisation software

Connectivity :

internet direct connection for remote flexible servicing

PORTIO 1D PORTIO 1DA

DUAL LANE

For increased capacity

DUAL LANE / DUAL LANE under ANGLE

The highest possible throughput on the smallest possible footprint can be reached with the PORTIO 1D, with its dual lane. Each lane has its controller and the 2 lanes run completely independently from each other. The PORTIO 1DA has the same features, but allows on top the ability to change the cutting angle.



0 °

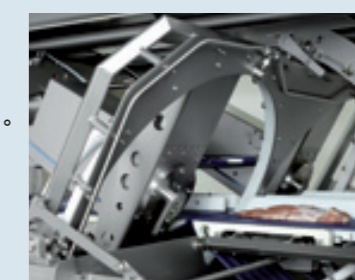

30 °

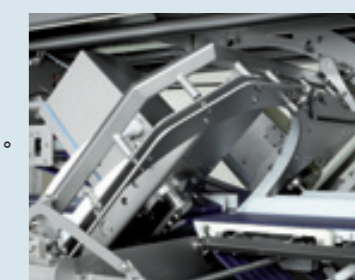

45 °

DIMENSIONS

PORTIO 1D/1DA	
I x w x h	138 x 78 x 63 inch
net weight	3750 lb



Application

	product	weight	capacity *	precision **
meat		55 - 150 g 2 - 5 oz	up to 1200 kg/hour up to 2700 lb/hour	2 g / 0,07 oz
		150 g and larger 5 oz and larger	up to 1600 kg/hour up to 3300 lb/hour	2 %
poultry		55 - 150 g 2 - 5 oz	up to 1000 kg/hour up to 2200 lb/hour	1,5 g / 0,05 oz
		150 g and larger 5 oz and larger	up to 1400 kg/hour up to 3000 lb/hour	1,5 %
fish		55 - 150 g 2 - 5 oz	up to 1000 kg/hour up to 2200 lb/hour	1,5 g / 0,05 oz
		150 g and larger 5 oz and larger	up to 1400 kg/hour up to 3000 lb/hour	1,5 %

* Actual capacity depends on raw material and cutting pattern.
** Standard deviation. Precision is product dependent.

DEMONSTRATION

In order to prove the benefits, MARELEC Food Technologies frequently organises demonstrations in-house or at the production facilities of its customers. This is the best way to convince you about the yields, throughput and quality of the cut with your own products.

BENEFITS

- Fast payback due to increased yields
- Reduced labor thanks to the available options
- Reduced giveaways due to highest accuracy
- Flexibility to change slicing specifications quickly and to cut under multiple angles
- Highest capacities due to fast cutting
- Space saving due to smallest footprint
- Highest hygiene due to open structure and ease of cleaning



IN BALANCE WITH YOUR NEEDS

MARELEC Food Technologies started with marine electronics for the trawler industry. Soon after, robust yet reliable weighing and sorting systems for the fish industry were developed both for use on shore as well as at sea. The unique features such as the high speed precision and the custom design were then integrated into solutions for the meat and poultry industry. Nowadays, we are world leading in designing and producing highly advanced weighing and sorting systems as well as intelligent portioning machines. A team of talented and enthusiastic designers and technicians are responsible for the in-house production of our systems. We focus on durable, innovative and flexible solutions. Furthermore we have a network of international agents in over 30 countries – who are available whenever someone needs advice, a fast delivery and service after sale.



MARELEC **Food Technologies**

Redanweg 15
8620 Nieuwpoort
Belgium
T +32 58 222 111
F +32 58 239 280
sales@marelec.com

www.marelec.com

